



inżynieria internetu przyszłości

System IP for supporting „Parallel Internets (Networks)”

Wojciech Burakowski, Halina Tarasiuk, Andrzej Beben
Warsaw University of Technology, Poland



inżynieria internetu przyszłości

Plan

- Recognized limitations of current Internet
- Currently investigated solution
- Conclusions

Recognized limitations

- Main limitation in wide open Internet and in NGN:
 - How to introduce some post-IP (other than TCP/IP) solutions for effective data transfer of traffic emitted by selected applications
- Investigated solution (in the frame of Future Internet Engineering project – more than 120 researchers – www.iip.net.pl)
 - We want to support a number of Parallel Internets (Networks), each working on different data and control planes
 - We introduce virtual infrastructure
 - We use devices enabling virtualization of network resources for creating virtual nodes and links
 - Apart TCP/IP (more precisely apart IP QoS) we implement:
 - Circuit Switching for handling mainly CBR traffic
 - Content Aware Network for content delivering





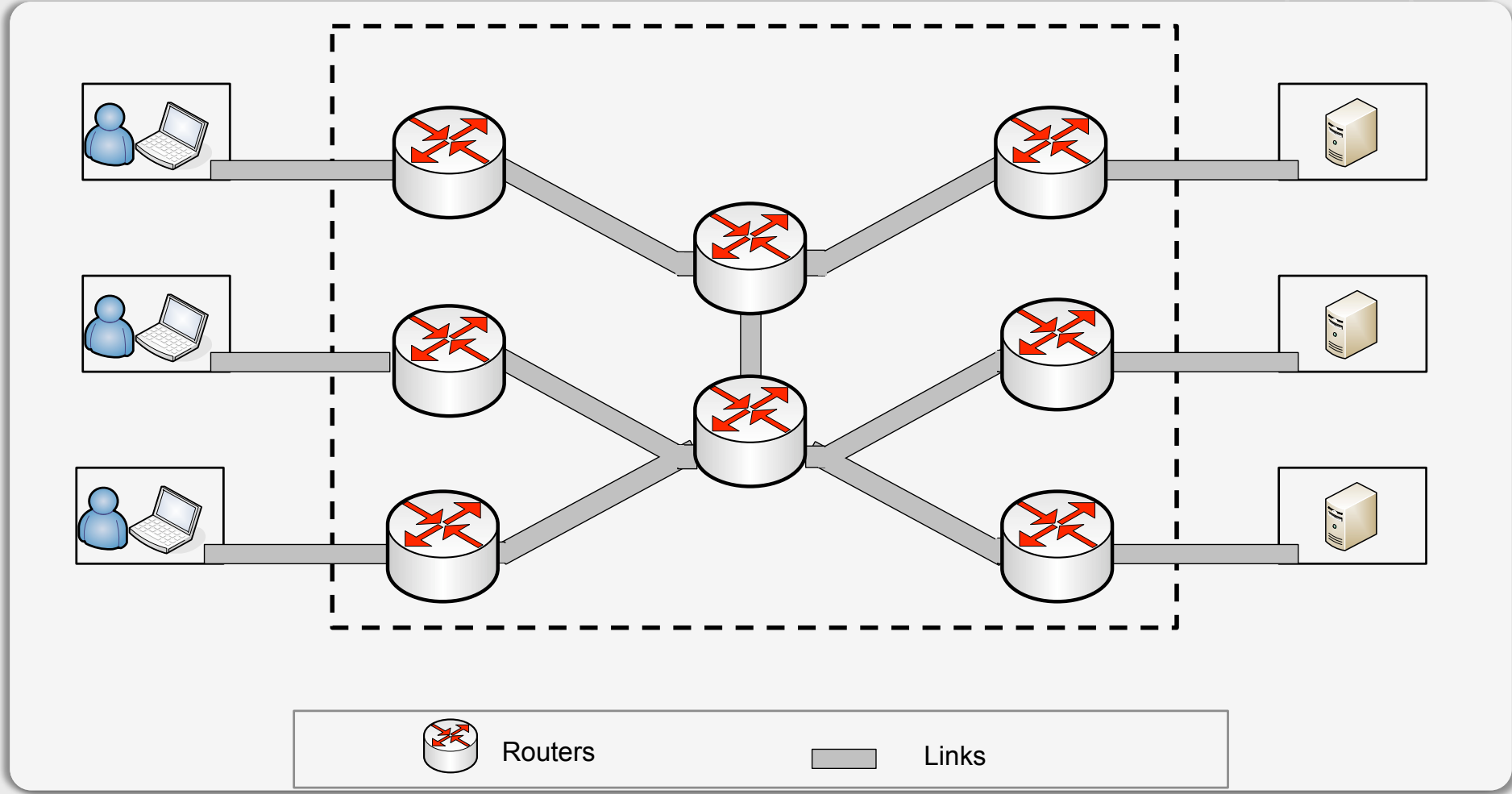

Current Internet: TCP/IP Technology



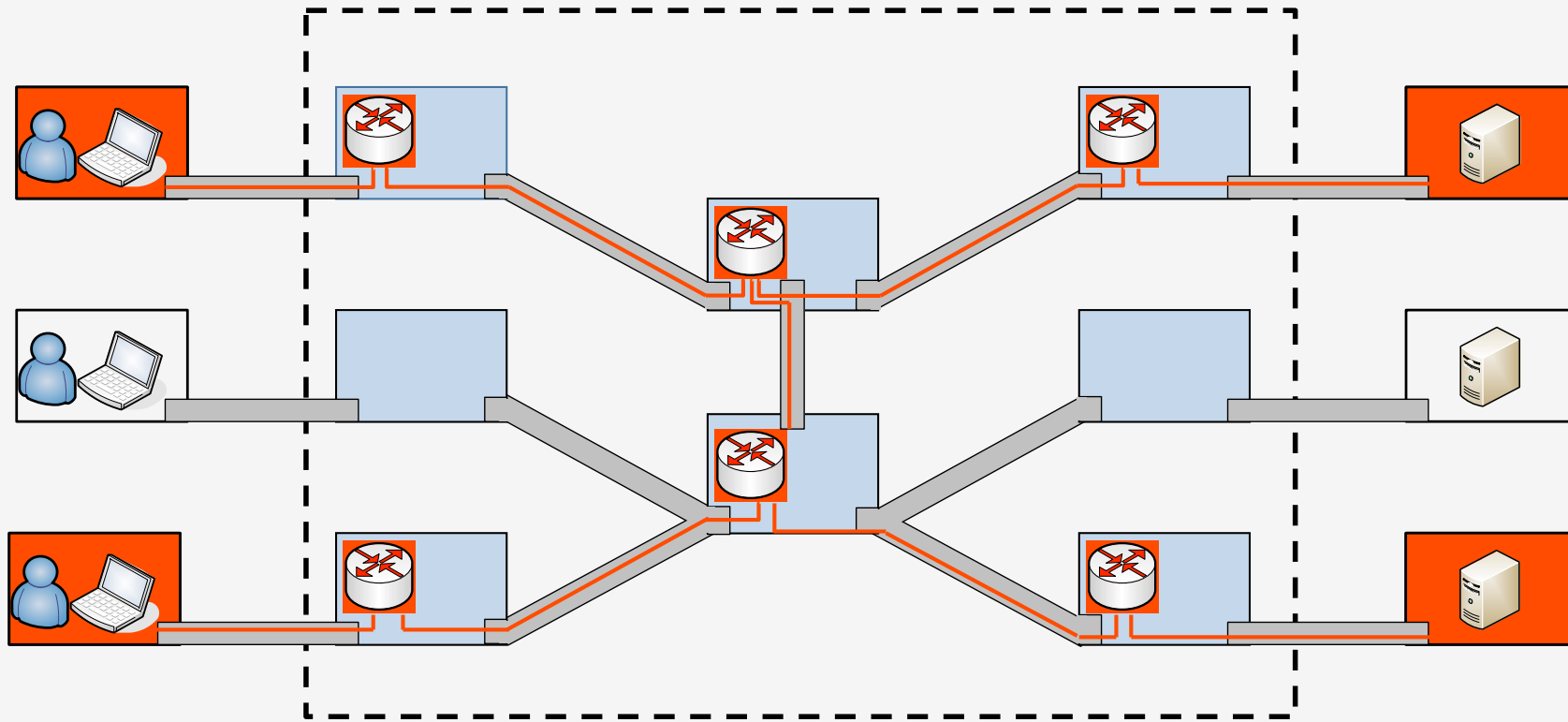

System IIP: Network A



	Net A		Net B		Device enabling virtualization
---	-------	---	-------	---	--------------------------------



System IIP : virtual networks A and B

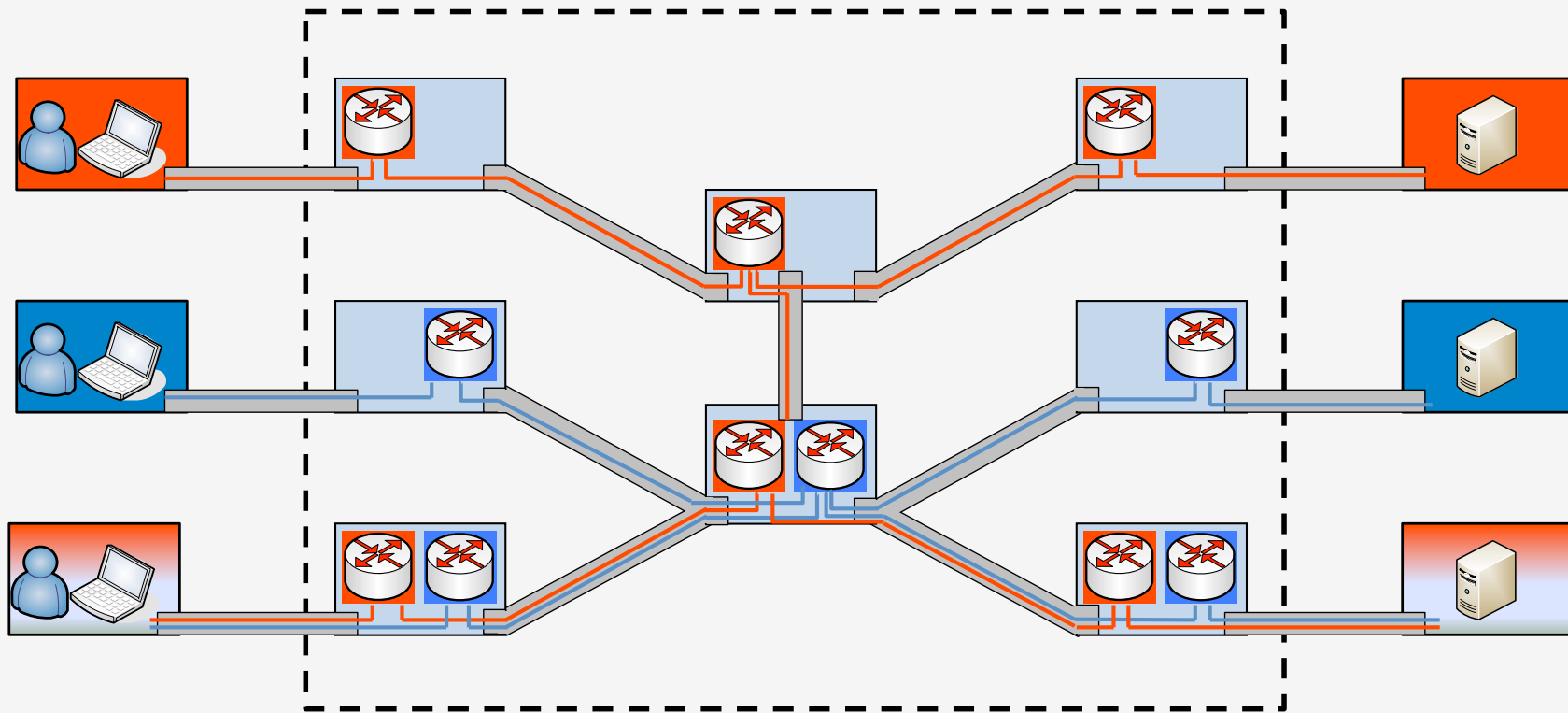

	Net A		Net B		Device enabling virtualization
---	-------	---	-------	---	--------------------------------



Architecture of the System IIP

Users

Applications/Services

Level 4
Virtual
networks



Level 3
Parallel
Internets

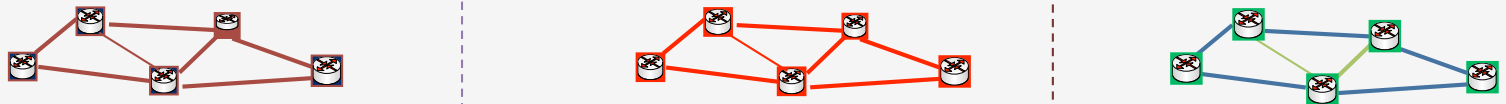

level 2
Virtualization



Creation of virtual resources for A, B and C

Level 1
Physical
infrastructure

Physical infrastructure enabling for creating virtual nodes, links, servers

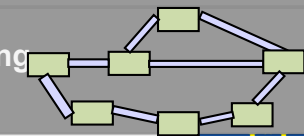



Ideal device enabling virtualization virtual nodes and links

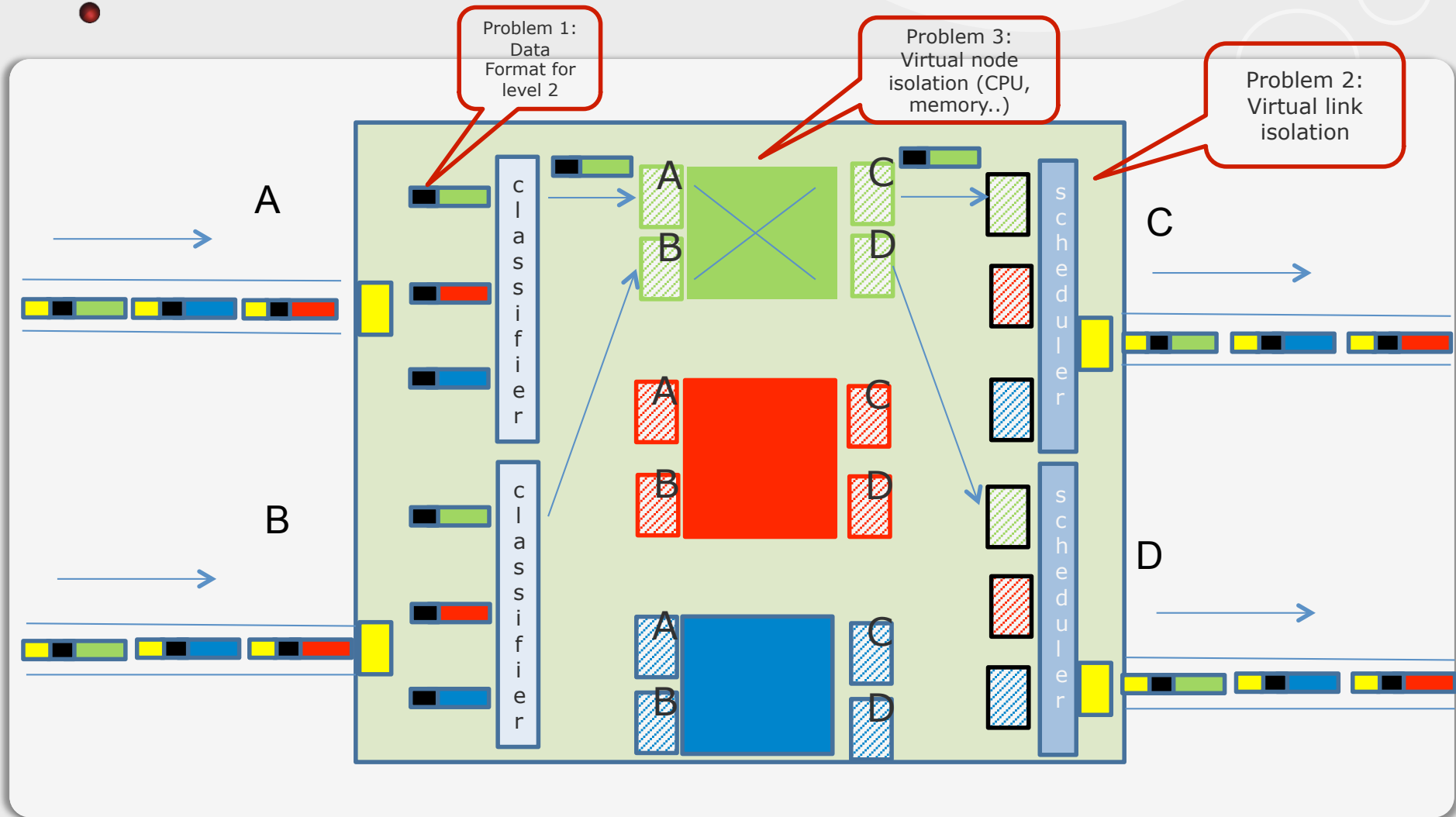



Conclusions

- Co-existing of Parallel Internets differing in data and control planes
- Virtual network infrastructure (virtual nodes and links)